

WSL-2500R

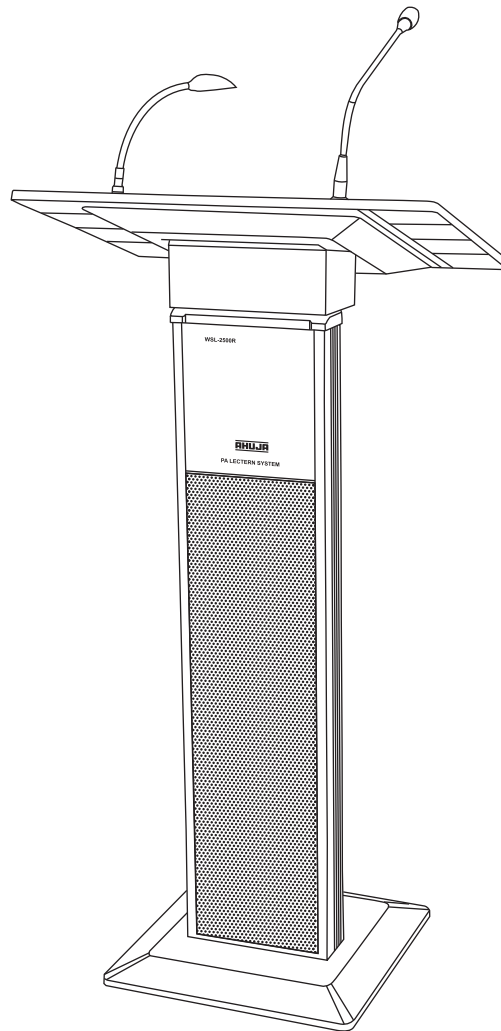

- ◆ Thank you for purchasing the AHUJA PA Lectern System.
- ◆ Please read this manual thoroughly before making connections and turning ON the power. Following the instructions in this manual will enable you to obtain optimum performance from your new AHUJA PA Lectern System.
- ◆ Please retain this manual for future reference.

• Safety Instructions

CAUTION: To reduce the risk of electric shock, do not remove rear control panel. No user serviceable parts inside. Refer servicing to qualified personnel only.

WARNING: To reduce the risk of fire or electrical shock, do not expose this equipment to rain or moisture.

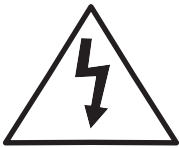

This symbol, wherever it appears, alerts you to the presence of uninsulated dangerous voltage inside the enclosure, that may be sufficient to constitute a risk of shock.



This symbol, wherever it appears, alerts you to important operating and maintenance instructions in the accompanying literature. Read the manual.

Detailed Safety Instructions: All the safety instructions in this manual should be read before operating this equipment.

Retain Instructions: The operation manual should be kept for future reference.

Follow Instructions: All operation and safety instructions should be followed.

Water and Moisture: In order to prevent any fire or shock hazard, do not expose this equipment to rain or moisture.

Power Source: The equipment should be connected only to a 220-240V 50Hz AC mains source.

Power-cord Protection: Do not cut, kink, damage or modify the power supply cord supplied with the equipment. Keep the power supply cord away from heaters & harmful chemicals. Do not place heavy objects on the power cord.

Operation on Generator: When operating WSL-2500R on a generator, make sure it is switched 'OFF' till the generator voltage has stabilized and then only switch the lectern amplifier ON.

Heat: The appliance should be situated away from heat sources such as radiators, amplifiers and other appliances that produce heat.

Replacing AC Mains Fuse: After disconnecting the AC mains and rectifying the defect in the equipment, change the fuse with another of the specified rating only. Insert and tighten the fuse holder completely to avoid any loose contact.

Cleaning: Before cleaning the PA Lectern System, unplug the equipment from the AC mains outlet. Do not use chemical solvents. Use only a clean & damp cloth for cleaning the equipment.

• Table of Contents

Contents	Page No
● Features and General Description of Product	4
● Instructions for Product Assembly	5
● Control Panel Features and Operations	7
● Wireless Handheld Transmitter Controls and Features	9
● Operating Instructions	10
● Specifications	11

• Features/General Description of Product

- Compact, versatile and easy-to-assemble wireless Lectern Amplifier with built in 40W amplifier.
- Contains a built-in speaker system consisting of 3nos. 6.5" (165mm) coated dual cone speakers. Provision given for connecting external speaker, if required.
- Supplied with a detachable gooseneck condenser microphone and a reading light for the podium top.
- Contains a built-in VHF wireless diversity receiver. High quality VHF wireless handheld transmitter supplied. (Available in one of different frequencies).
- Provision for connecting a wired microphone through a 6.3mm phone jack or a line source through an XLR connector.
- Built-in digital MP3 recording and playback facility. Recording or playback can be done using either a USB pen drive or a SD card
- Facility for connecting a stereo auxiliary source through L&R RCA plug. It accepts four different sensitivities of auxiliary signal which are selectable through a slide switch.
- Separate output connectors for LINE OUT & REC OUT through mini male XLR & 6.3mm phone socket respectively, allowing the lectern system to be connected to external amplifiers for further amplification, if required.
- Handheld wireless transmitter & gooseneck podium microphone have voice priority over all other inputs. This feature can be switched ON or OFF through a slide switch.
- Tonal adjustment can be done through cut-boost type Bass & Treble controls.
- Rugged & stable floor standing base. Can be fixed to the floor with brackets (provided), if required.
- Operates on 240V 50Hz mains supply.
- For assembly instructions see pages 5 & 6.

• Instructions for Product Assembly

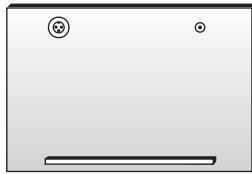

Podium Top

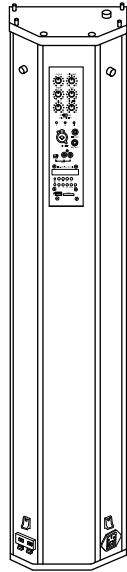

Lectern Column

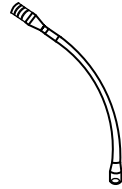

Gooseneck Microphone

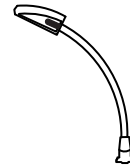

Gooseneck Light



02 nos. Antenna

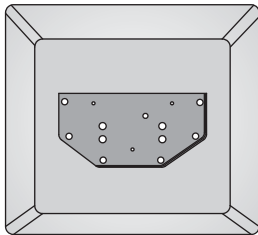

Bottom Stand

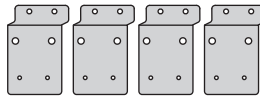

04 nos. Mounting Clamps

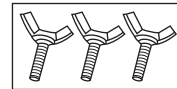

03 nos. Fly Bolt

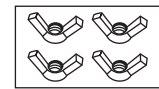

04 nos. Fly Nuts

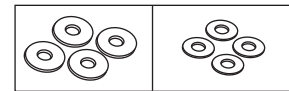

04 nos. each of Rubber & Metal Washer

STEP-1: Fixing of mounting clamps to the bottom stand.

- i) Unscrew 04 nos. each of rubber base feet and black screw from the bottom stand.

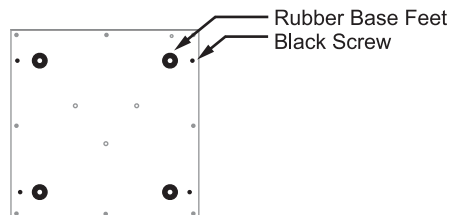

- ii) Take a mounting clamp, place it on the bottom side of the bottom stand and then tighten it with the black screw and screw of the rubber base feet.
- iii) Similarly, remaining three mounting clamps should be fixed to the bottom stand.

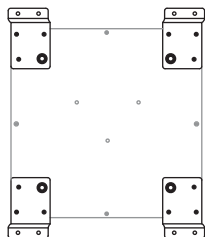

STEP-2: Fixing of Lectern Column to the bottom stand.

- i) Place the lectern column into the matching slot available in the bottom stand.
- ii) Tighten the bottom stand to the lectern column through 03 nos of fly bolts from bottom side of the stand.

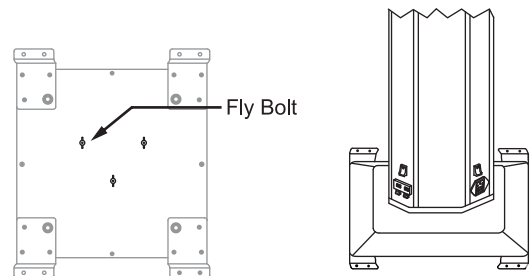

STEP-3: Fixing of Podium Top to the Lectern Column

- i) Place the podium top over the upper end of the lectern column so that the podium top slopes towards the rear side (where controls & USB module are fitted).
- ii) Tighten it by using 04 nos. of rubber washers, 04 nos. of metal washers and 04 nos. of fly nuts.

• Instructions for Product Assembly

- iii) Screw on the 4-pin female connector coming out of the podium top to the 4-pin male connector which is fitted on the top end of the wireless lectern amplifier.

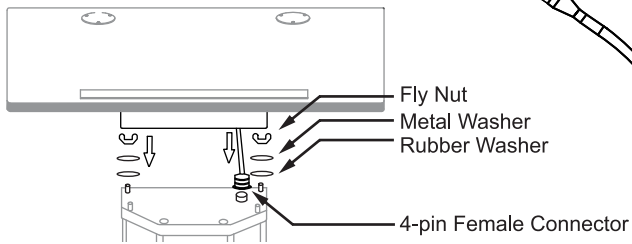

STEP-4: Fix 02 nos. of antenna in their respective connectors.

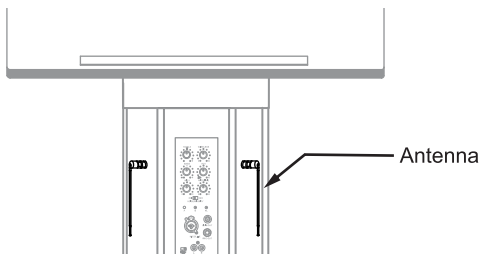

STEP-5: Fix the gooseneck condenser microphone and podium gooseneck light in their respective connectors available on the podium top.

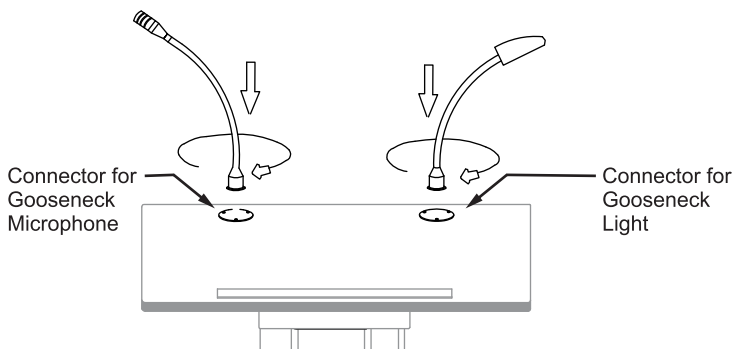

NOTE: Before switching ON, plug the AC cord in the AC socket of lectern column and connect the other end to a AC mains socket. Switch ON the power switch at lower end of the lectern column. A suitable 4 ohm speaker system can be connected to the external speaker terminal, if an external speaker is required. Other input signal sources like microphone, CD player and USB pen drive can be connected for performing desired operations.

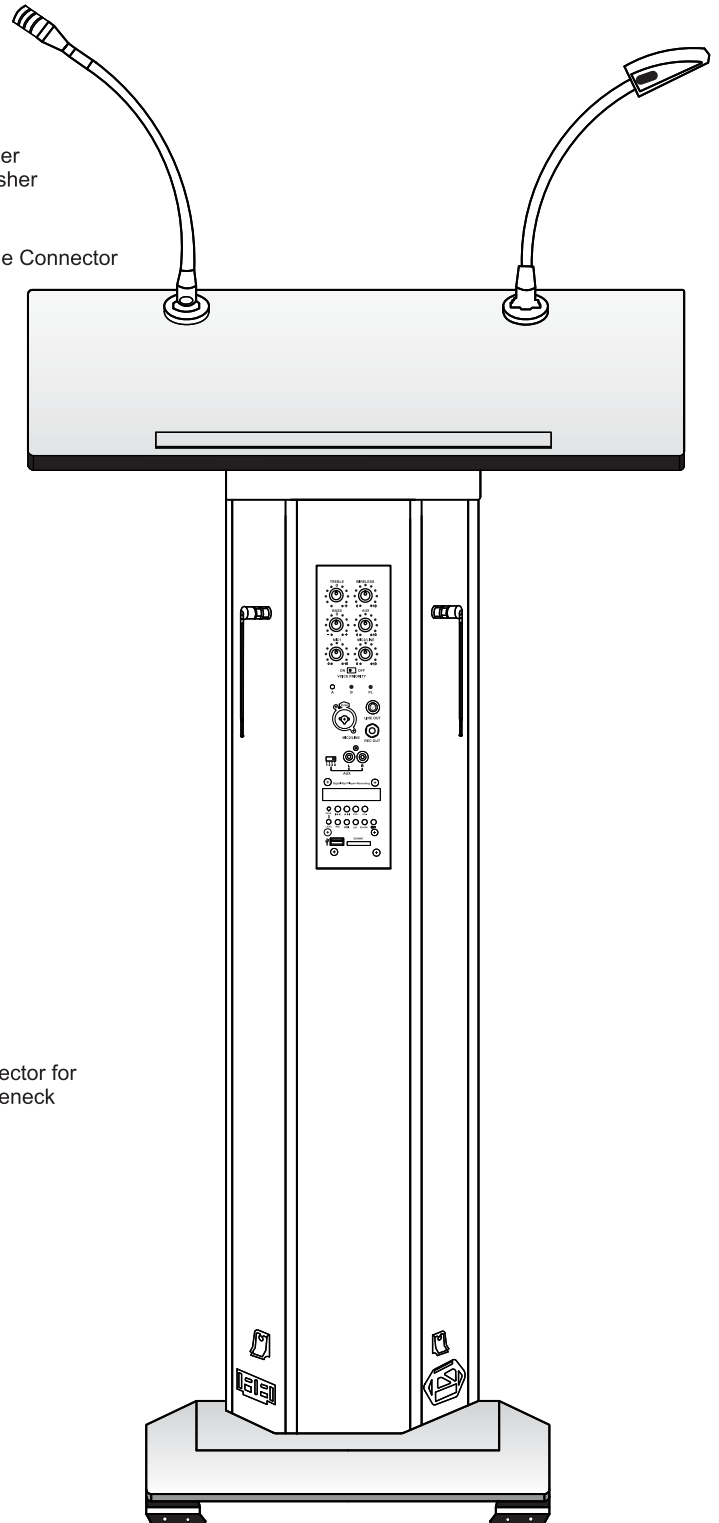

• Controls Panel Features and Operations

1. **ON/OFF switch for Gooseneck Light:** This switch is located on the bottom side of the podium top which can be used to switch the gooseneck light ON or OFF.
2. **Gooseneck Light**
3. **Gooseneck Microphone:** This detachable gooseneck microphone is fixed on the male XLR socket provided on the podium.
4. **SPEAKER Selector Switch:** When this switch is kept in INTERNAL SPEAKER mode, the built-in speaker column is in operation. If it is desired to use some other speaker then the switch is kept in EXTERNAL SPEAKER mode.
5. **Terminal for External Speaker :** This spring loaded push terminal is used for connecting an external 4Ω speaker system. Keep switch (4) in EXTERNAL SPEAKER position when using this external speaker.
6. **AC socket with built-in fuse:** AC socket for connecting the detachable AC lead, as supplied along with. This has a built-in AC fuse of T500mAL rating.
7. **Power Switch:** Press the lower portion of this switch to switch ON the lectern column.
8. **Telescopic Antenna A&B:** When wireless transmitter is in use, both the antenna should be fully stretched and direction adjusted so as to obtain best reception.
9. **Control Panel:**
 - A. **Treble Control:** For attenuating or boosting the signal level of high frequencies.
 - B. **BASS Control:** For attenuating or boosting the signal level of low frequencies.
 - C. **MIC-1 Volume Control:** For controlling the signal level of the gooseneck condenser microphone which is connected on the podium top.
 - D. **MIC-2/LINE Input Socket:** This combo connector can accept unbalanced signal from a low impedance microphone through a 6.3mm phone jack plug. Alternatively, it can accept balanced signal from a LINE level source through an XLR male plug.
 - E. **AUX Sensitivity Selector Switch:** For selecting appropriate level of AUX input signal through a four position slide switch. For connecting an Ahuja PA mixer to AUX input of lectern column keep the sensitivity selector switch in position 4.
 - F. **Wireless Transmitter Volume Control:** For controlling the signal level of the handheld wireless transmitter.
 - G. **AUX Volume Control:** For controlling the level of the signal connected to AUX RCA sockets.
 - H. **MIC-2/LINE Volume Control:** For controlling the level of the signal connected to MIC-2/LINE combo socket.
 - I. **VOICE PRIORITY SWITCH:** When the slide switch is in ON position, both WIRELESS transmitter and MIC-1 attain priority over MIC-2, LINE, MP3 Player and AUX inputs. In other words, MIC2, LINE, AUX & MP3 PLAYER/RECORDER signals will be attenuated when there is a signal from the fitted gooseneck microphone or the wireless transmitter supplied. Voice priority is mainly put ON for delivering important messages during a program, without having to adjust any control, to attenuate other signals which may be already playing. If this feature is not required, keep this switch in OFF position.

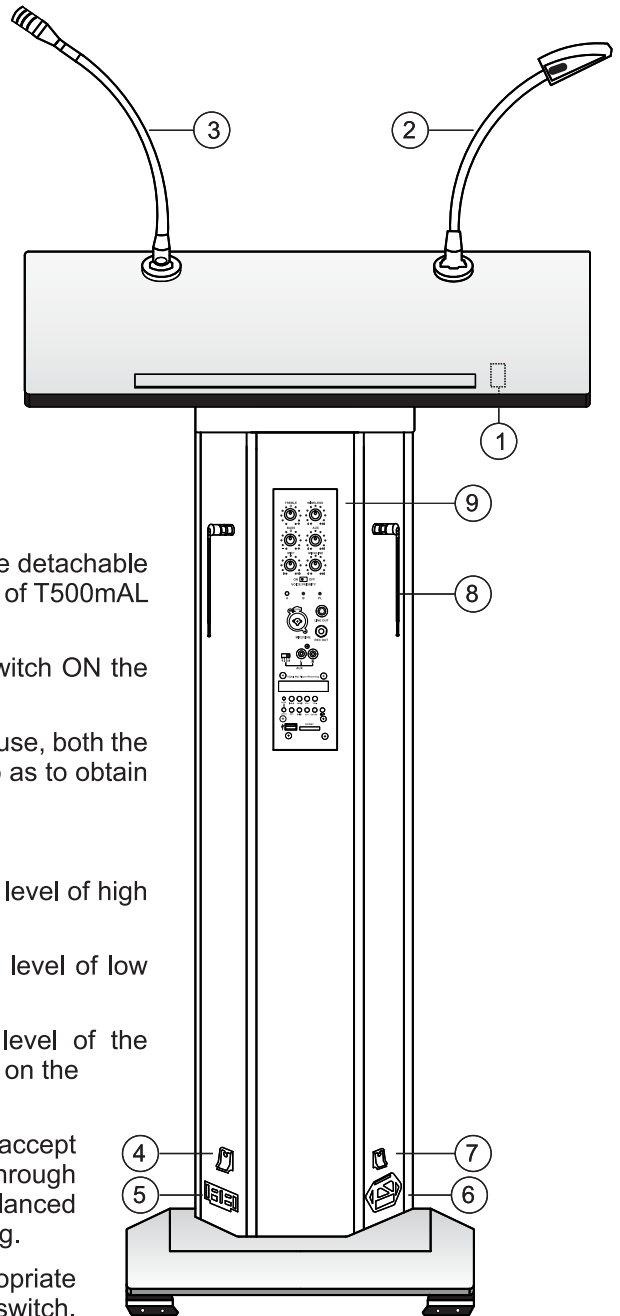

• Controls Panel Features and Operations

- J. RF LEDs:** Green LED 'A' glows to indicate that antenna A is being used for the reception of RF signal. Similarly green LED 'B' glows to indicate that antenna B is being used for the reception of RF signal. Only one of the two LEDs will glow at a time due to diversity receiver circuitry.
- K. Power LED:** Red LED glows when the AC mains supply to the lectern amplifier is switched ON.
- L. LINE OUTPUT Mini XLR Socket:** Provides line level outputs through a 4 pin mini XLR male socket for connecting another lectern or recording purposes.
- M. RECORD OUTPUT Jack Socket:** Unbalanced audio output is available through this 6.3mm phone jack socket. This output is provided for connecting to a cassette recorder or a separate USB recorder. Record output can also be used for connecting a high power PA amplifier.
- N. AUX Input RCA Socket:** For accepting stereo signal from an auxiliary source like a USB player, CD player, Tape player, Tuner, Audio Mixer etc.,
- O. Digital MP3 Play + Recording Facility**
- LCD Display:** Displays 3 digits of the track being played i.e 001 to 999. If number exceeds 999, it will reset to 001.
 - ▶▶ Next:** Press NEXT to select forward music track. Pressing NEXT repeatedly will move the system to successively next forward tracks.
 - ◀◀ Prev:** Press PREV to select the previous track. Pressing PREV repeatedly will move the system to successively previous tracks.
 - PEAK:** The glowing of this red LED indicates that the recording level is high & should be reduced through LEVEL control
 - LEVEL:** The level of recording signal can be adjusted by this control. It can be adjusted by inserting a suitable screw driver into the hole and then turning the control.
 - REC:** Press REC button to start recording function.
 - ▶|| Play/Pause:** Press PLAY/PAUSE once to pause if music is already playing. Press PLAY/PAUSE again to play.
 - USB Connector:** Insert the USB drive here. While inserting USB drive into the USB connector, hold the USB drive in such a way that hollow part of the USB drive is upwards as shown in figure. Do not apply pressure in an attempt to forcibly insert a USB drive which is not in correct orientation.

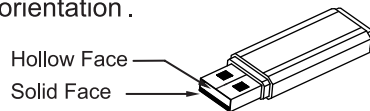

- VOL+:** Press VOL+ once to increase the playback output level step by step up to 15 point. For increasing the output level quickly to the desired level, keep VOL+ pressed till it reaches the desired position & then release the button.

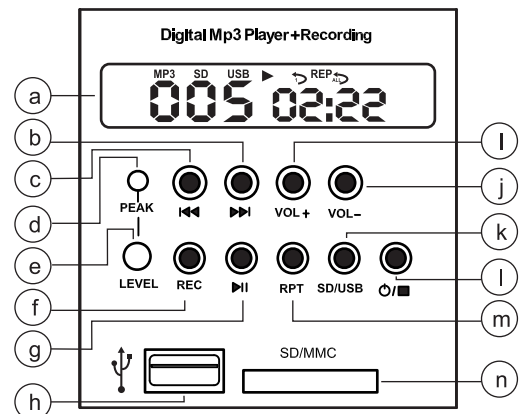
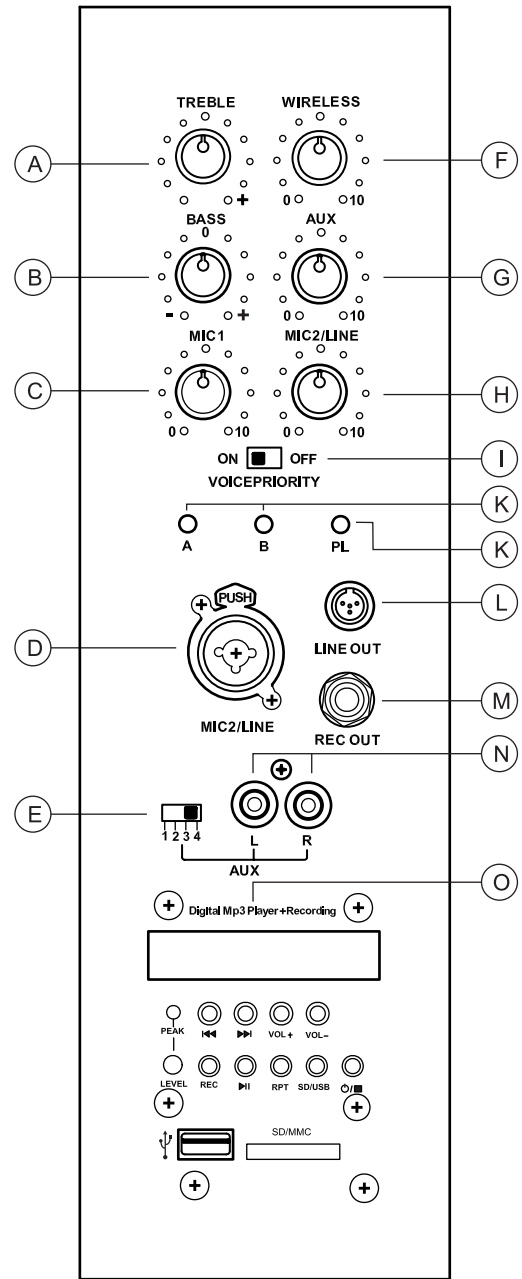

• Controls Panel Features and Operations

- j. **VOL-:** Press VOL- once to decrease the playback output level step by step up to 00 point. For decreasing the output level quickly to the desired level, keep VOL- pressed till it reaches the desired position & then release the button.
- k. **SD/USB:** Press SD/USB once to select between SD/MMC card and USB when both are inserted.
- l. **⏻/■ :** If MP3 recorder is OFF, keep ⏻/■ pressed for 3 sec. to switch it ON. Press this button again for 3 sec. to switch OFF the MP3 recorder. During recording function, press this switch once to STOP (■) recording.
- m. **RPT:** This repeat RPT button has four options:
 - i) If there is no display of RPT, repeat function is not active.
 - ii) Press RPT button once to display RPT which means repeating a track randomly.
 - iii) Press once again to display ↻ RPT which indicates that all the tracks get repeated.
 - iv) Press once again to display ⏮ RPT which indicates that the current track will keep repeating. Press again to cancel repeat function.
- n. **SD/MMC Card Connector:** Insert the SD/MMC Card into its appropriate slot to play. When taking out the card, pull the card to take out. While inserting SD/MMC card into the slot, ensure that the card is inserted in such a way that all pins are facing downward and cut is towards right as shown in figure.

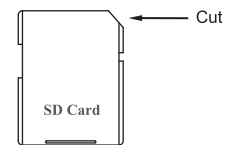



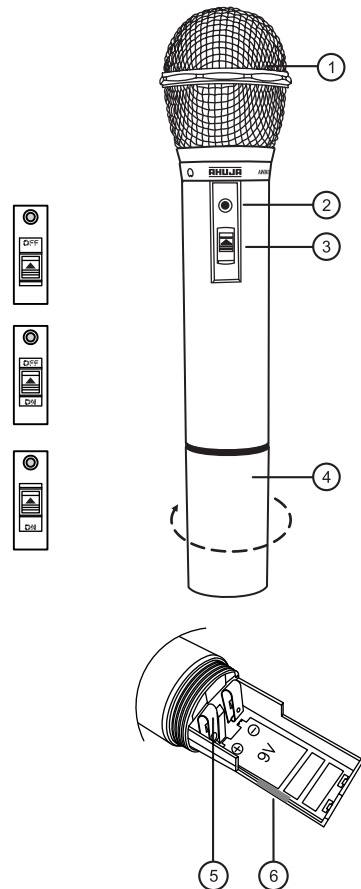

• Wireless Handheld Transmitter Controls and Features

1. **Transmitter Grill**
Steel chrome plated grill with anti-roll ring.
2. **LED**
This red LED glows when the transmitter switch is moved from OFF position to center or top position. It indicates RF signal is ON.
3. **Switch**
The Slide switch has 3 positions:
 - a. At the lowest position, the transmitter is completely OFF.
 - b. At the center position, the transmitter transmits only the RF signal which is indicated by glowing of red LED in the transmitter and green RF LED in the receiver of meeting amplifier. There is no audio output.
 - c. At the top position, the transmitter also transmits the audio signal. While speaking into the transmitter, **ensure that the transmitter switch is in top position.**
4. **Cover for 9V Battery Housing**
Rotate the cover anti-clockwise to unscrew and gain access to the battery compartment which consists of connecting strips & housing for a 9V battery.
5. **Connecting strips for 9V Battery**
Insert the 9V battery in correct polarity so that it gets locked against these connecting strips



• Operating Instructions

1. After assembling PA Lectern System, connect it to a 240V AC mains outlet through a detachable AC lead as supplied along with.
2. Switch ON the supply through power switch (7). Ensure that all volume controls are at minimum position.
3. **Gooseneck Microphone Function:** The gooseneck condenser microphone gets ON and its red ring LED lights up when power switch is switched ON. The gooseneck microphone grill should have a foam wind shield which minimises pop and breath noise. Speak a few words through the microphone and adjust the desired output level through MIC1 volume control (9C) on the control panel.
4. **Wired Microphone Function:** Connect any Ahuja wired microphone to MIC2 input socket (9D), if required. Speak into the microphone and adjust MIC2/LINE volume control for suitable sound output level.
5. **Wireless Transmitter Function:** PA lectern system is supplied with a handheld VHF wireless transmitter and the diversity receiver is built into the lectern column. Insert a 9V battery into the transmitter and switch it ON. Ensure that the two antenna A&B (8) are fully stretched and kept away from any other reflecting surfaces and obstructions. Carry out a 'walk through' test of the wireless system to ensure that there are no drop-outs in the performing area. The output level is adjustable through wireless volume control (9F).
6. **USB/SD Playback:** For playing pre-recorded music or messages through the lectern, insert the USB pen drive or SD/MMC card into its appropriate slot, switch the MP3 module ON, press PLAY button and operate as shown under (O) on page 8.
7. **USB/SD Recording:** After switching ON the MP3 module, press REC button once. The display should show rEC. Press REC button once again. Now the word rEC on the display will flash for about 10 seconds. After this, the recording will take place and the display will show time elapsed. To obtain adequate recording level, adjust the LEVEL control till the PEAK LED starts to glow occasionally. Press  button once to stop the recording.

To access this recording again during playback, keep the  NEXT or  PREV buttons pressed for scanning through all the folders. The recordings made through the lectern MP3 module will be displayed as FrE1, FrE2 etc. folders. Release the  NEXT or  PREV button when the desired FrE folder is reached and the module will start playing back this folder.
8. **Aux Input Function:** The output signal level of various auxiliary sources like CD player, PA mixer etc., can vary from 100mV to 1V. In order to obtain best sensitivity matching, the AUX input of lectern column has a sensitivity selector switch (9E). Connect the auxiliary source, select appropriate sensitivity and adjust AUX volume control (9G) for desired output levels. For example with an Ahuja PA Mixer keep the sensitivity selector switch in position 4 .
9. **External Speaker:** The built-in speakers of the lectern column can be replaced by external speaker system of 4 ohm impedance. To do so, put speaker selector switch (4) in External Speaker position. Connect a suitable speaker to the Terminal for external speaker (5) and adjust BASS (9B) and TREBLE (9A) controls to achieve desired tonal response.

• Specifications

LECTERN COLUMN	
Audio Power Output	40 Watts Max.
Speaker Impedance (External)	4Ω
Input Channels Sensitivity	Mic-1: 3.0mV, Mic-2: 1.8mV, Line: 100mV Aux Position-1: 100mV, Aux Position-2: 180mV, Aux Position-3: 300mV, Aux Position-4: 700mV
Frequency Response	100-16,000Hz
Tone Control	Bass ±6dB at 80Hz, Treble ±6dB at 8kHz
REC. Output	1V
Power Supply	AC 220-240V, 50/60Hz
Power Consumption	AC 100W
Maximum Deviation	± 40kHz
Wireless Receiving Mode	Quartz controlled fixed frequency
Wireless Modulation Mode	FM (F3E)
Wireless Range	Over 15m in free space (line of sight)
Dimensions	W420 × H1135 × D580 mm
Weight	18.3 kg approx.
WIRELESS TRANSMITTER	
Transmitter	Dynamic Unidirectional
Type of Emission	FM (F3E)
Frequency Stability	±0.005%
Max. Modulation	±40kHz
Spurious Emissions	45 dB
Pre-emphasis	50μ sec.
RF Output Power	15mW (max.)
Frequency Response	50 - 15,000Hz
Dynamic Range	100dB
Battery	9V
Current Drain	30 mA
Dimensions	Ø55 × L244 mm
Weight (w/o battery)	0.20kg approx.

- Design and Specifications are subject to change without notice owing to continuous product upgradation.
- Technical specifications are subject to production tolerances.

Contents/Parts Supplied

Lectern Column	1 no.	AC Cable	1 no.
Podium Top	1 no.	Mounting Clamp	4 nos.
Bottom Stand	1 no.	Fly Bolt	3 nos.
Wireless Handheld Transmitter	1 no.	Fly Nuts	4 nos.
Gooseneck Condenser Microphone (with Foam Windshield)	1 no.	Rubber Washer	4 nos.
Gooseneck Light	1 no.	Metal Washer	4 nos.
Antenna	2 nos.	9V Battery	1 no.
		Operation Manual	1 no.

AHUJA RADIOS

215, Okhla Industrial Estate, New Delhi-110020, INDIA
C-45, Phase-II, Noida-201305 (UP) INDIA ● 3, Okhla Industrial Estate, New Delhi-110020 INDIA
Tel.: +91-11-26831549, 41612474 Fax: +91-11-26847287 E-mail: ahuja@ahujaradios.com
Website: www.ahujaradios.com

- Design and Specifications are subject to change without notice owing to continuous product up-gradation
- Technical specifications are subject to production tolerances.
- We cannot be held responsible for printing errors, should they occur.
- **AHUJA** is a registered trademark of Ahuja Radios in India and other countries.
- © Copyright Ahuja Radios, 2013. All rights reserved. Any unauthorized reproduction or use of logos, images or design elements is strictly prohibited by law.
- No part of this compilation may be reproduced in any manner or translated without written permission.

AHUJA®